



THERMAL IMAGING BINOCULAR TG1



**USER GUIDE
CERTIFICATE**

CONTENTS

1. Package	3
2. Precautions	3
3. Purpose	3
4. Technical characteristics	4
5. Design and control	5
6. Setting-up procedures and performance inspection	6
7. Use of additional accessories	7
8. Possible defects	7
9. Storage and transportation	8
10. Quality test certificate	9
11. Warranty	9
12. Manufacturer	10

1. Package

Thermal binocular TG1			1 pc.
Objective	<input type="checkbox"/> F50	<input type="checkbox"/> F75	
Case			1 pc.
User guide (certificate)			1 pc.

2. Precautions

- Protect the device from shock.
- Don't wipe objective and eyepiece lenses with hard abrasive materials.
- Don't store the device with power sources.

IMPORTANT!

It is strongly forbidden to direct thermal device to the sun and other sources of intensive thermal radiation temperature of which exceeds 500 C°!

3. Purpose

The binocular is intended to observe movable and immovable objects in conditions of various illumination and limited visibility (fog, dust, etc.). With the help of the device one can indicate places having temperature background different from natural, for example, hot liquid, gas leakage, heating of local surfaces etc.

4. Technical characteristics

Model	TG1	
Sensor: pixels / detector pitch	384x288 / 17um	
Microdisplays: type / pixels	OLED / 1024x768	
Focal, length/aperture ratio	F50 /1,0	F75 /1,0
Magnification, X	3,5	5,3
Angle of view, degr	7,5°x5,6°	5°x3.8°
Digital zoom	x2, x4	
Detection range (obj.0.5x1.8m), m	up to 1200	up to 1700
Spectral range, micrometer	8 - 14	
Frequency, Hz	50	
Palette / inversion	9 types / yes	
Diopter adjustment, diopters	±4	
Voltage/Battery type	9V / 3 x CR123A Lithium	
Operating time (+20°C), hours	4,5	
Operation temperature range, °C	-40 ... +50	
Degree of protection according to IEC 60529 (optional)	IPX5 (IPX7)	
Dimensions, mm	213x139x66	213x139x70
Weight, kg	1,0	1,2
Plug for external power supply	present	
Manual adjustment of sensor reinforcement	present	
Manual adjustment of microdisplay brightness	present	
Video output	present	

5. Design and control

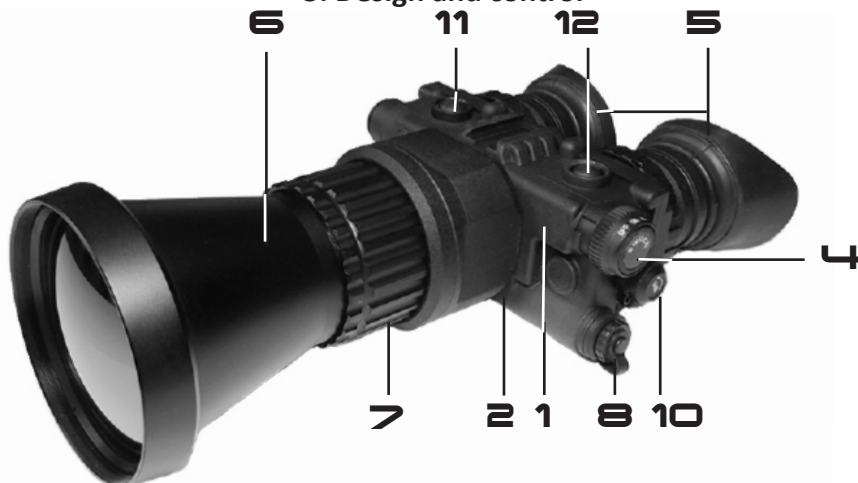

1. Body
2. Battery compartment
3. Battery compartment
4. On/off-switcher
5. Eyepieces with diopter adjustment rings
6. Objective
7. Objective adjustment ring
8. Outer power source slot
9. Video output
10. Gain/brightness adjustment
11. Digital zoom button
12. Image polarity button
13. Cartridge of dehydrator
14. Switch-on indicator



6. Setting-up procedures and performance inspection

Insert power elements due to polarity indicated on the battery compartment body.

Turn on the switcher (4) and make sure that on-indication lights (14). If on-indication doesn't light change power elements. After the device has been switched-on wait till an image appears on display (in the eyepieces). Time of switching-on displays and readiness of the device is not more than 8 seconds.

With the help of diopter adjustment rings (5) reach maximal possible sharp image. Guide yourself by service inscriptions and marks on display. After it direct the device to the selected object and reach sharp image of the observed object by rotating objective (6) adjustment ring (7).

Choose optimal magnification (chosen multiplicity is reflected on display as 1x, 2x, 4x) with the help of digital zoom button (11).

Choose optimal polarity of image with the help of polarity change button (12) (it is displayed in the left upper corner  or ).

Black-and-white palette is installed on default (Palette 1), it depicts observed objects in the mode hot – black or hot-white. In order to change the palette, make sure, there is no indication of other editing modes in message line; after it press and hold on INVERT (12) button during 3-5 seconds till inscription Palette appears in the message line. Then, press INVERT (12) button successively and choose necessary image palette (9 types). To exit palette change mode press and hold on button (12) during 3-5 seconds till inscription Palette disappears in the message line.

Pay attention, after the device is switched off color palette adjustments don't change.

In order to adjust sensor sensitivity make sure the mode of sensitivity adjustment is displayed in the message line (inscription Gain XX, XX - value -10 up to +10, if in the message line inscription BRGT. XX is displayed press shortly GAIN (10) handle in order to turn to sensitivity adjustment mode), after it rotate gain/brightness adjustment handle GAIN (10). It is adjusted in the way the data changes in the message line.

In order to adjust micro display brightness press shortly gain/brightness

adjustment handle (10) to turn to brightness adjustment mode (inscription Gain XX in the message line changes to BRGT. XX). Choose an optimal brightness level of micro display by rotating handle. Brightness adjustment varies from 0 up to 25.

7. Use of the device with additional accessories

There is an opportunity in the device to connect outer power source with 10...14,6 V (car embedded network) through the slot (8) or outer power source with 8-14,5 V and plug of JACK 2.1. standard.

To record image you should use standard video cable with RCA plug to connect the binocular and corresponding plug for the used video recording device. When the binocular is switched on (first position of switcher 4) video is given to the plug (9).

You may switch off microdisplays during video mode by rotating the switcher (4) to the next position. When recording the image, guide yourself by the instructions (menu) of video recording device.

Video type given from the binocular to video recording device is CVBS.

8. Possible defects and methods of their removal

Your binocular is a complex optomechanical device. Its repair and service may be fulfilled only in conditions of manufacturer.

If switch-on indicator doesn't shine or blink after switching- on the binocular, and image is absent or blinks in the eyepiece, so may be power elements are uncharged or junctions in battery compartment are broken. Change power elements; inspect junction at the battery compartment cap (3) and junction inside the battery compartment.

There shouldn't be any corrosion traces and any dirtying. If power elements are changed and junction cleaning doesn't help, if any other defects or failures appear, don't try to disassemble the binocular by yourself and repair it. It may lead to greater failures and warranty loss. Turn to the vendor or to the manufacturer.

9. Storage and transportation

Device is to be kept in case in dry heated and aired room with relative humidity up to 80% with temperature 5°C - 30°C.

In the room there shouldn't be any acid fumes, alkali and other aggressive dirt in the air.

While preparing the device for long-term storage, you need to do the following things:

- lubricate with any gun oil uncolored metal parts, lubricate cap thread of battery contact, battery compartment thread, lubricate inner contact of battery compartment with any a gun oil, dry up the device.

Transportation conditions depend on climatic factors (temperature -50 - + 50 °C, relative humidity not more than 98 % at 25 °C).

Device can be transported by any kind of transport, in roofed vehicles according to transportation rules at the given kind of transport.

10. Quality test certificate

Thermal imaging binocular **TG1**

Serial №

Sensor №

Date of production

Representative of quality department

11. Warranty

- Manufacturer guarantees that the thermal binocular quality corresponds to technical demands if storage, transportation and operation rules and conditions are adhered to.
- Warranty period constitutes 12 months.
- Manufacturer repairs the binocular or changes it in case of producer - caused failure during warranty period.

12. Manufacturer

Scientific-productive firm «Dipol»

Lazo str. 115A
210033 Vitebsk
Republic of Belarus

Tel. +375 212 53 00 63
Fax. +375 212 53 00 68

WEB: [http:// dipol.biz](http://dipol.biz)
Email: contact@dipol.biz

For notes

Scientific-productive firm

"DIPOL"

Lazo str. 115A
210033 Vitebsk
Republic of Belarus

Tel. +375 212 53 00 63
Fax. +375 212 53 00 68
WEB: [http:// dipol.biz](http://dipol.biz):
Email: contact@dipol.biz

