



DRONE PRO 10X DRONE PRO 15X

Digital Night Vision Riflescope



OPERATION AND MAINTENANCE MANUAL

Important Export Restrictions! Commodities, products, technologies and services of this manual are controlled by the U.S. Department of State Office of Defense Trade Controls, in accordance with International Traffic in Arms (ITAR), Title 22, Code of Federal Regulations Part 120-130 and/or by the Export Administration Regulations (EAR) of U.S. Department of Commerce. At any time when a license or a written approval of the U.S. Government is applicable to it, it is illegal and strictly forbidden to export, intend to export, transfer in any other manner whatsoever, sell any hardware or technical data, provide any associated service to any non-U.S. resident, beyond or within the United States territory, until the valid license or written approval has been issued by the Departments of the U.S. Government having jurisdiction. Additionally U.S. law prohibits the sale, transfer, or export of items to certain restricted parties, destinations, and embargoed countries, as identified on lists maintained by the U.S. Department of State, the U.S. Department of Commerce, and the U.S. Department of Treasury. It is the responsibility of the Customer to be aware of these lists. The sale, transfer, transportation, or shipment outside of the U.S. of any product prohibited or restricted for export without complying with U.S. export control laws and regulations, including proper export licensing, documentation or authorization, is unlawful and may result in civil and/or criminal penalties and/or constitute a federal crime. Diversion contrary to U.S. law is strictly prohibited.



SAFETY SUMMARY

Before operating this product, you must carefully study this Operation and Maintenance Manual.

The Armasight Drone PRO Digital Night Vision Riflescope is a precision electro-optical instrument and requires careful handling. To avoid physical danger to the user and damage to the equipment, follow all WARNINGS, CAUTIONS and NOTES.

Below are definitions of the alerts that will appear throughout this Manual:

WARNING – Identifies a clear danger to the person operating the equipment.

CAUTION – Identifies risk of damage to the equipment.

NOTE – Highlights essential procedures, conditions, and statements, or conveys important instructional data to the user.



WARNING:

Always make sure your firearm is unloaded before you place the scope on the firearm. Reconfirm that the chamber is empty if you stop the procedure then resume later. Safe handling rules should be followed at all times.



WARNING:

If a scope is mounted too far to the rear, the eyepiece can injure the shooter's brow. Shooting at an uphill angle also increases this hazard because it shortens the distance between the brow and the rear of the scope. For this reason, Armasight scopes are engineered to provide generous eye relief. Therefore, when mounting your scope, we recommend positioning it as far forward in the mounts as possible to take full advantage of this generous eye relief. With hard-recoiling rifles, serious injury or even death can result from eyepiece impact with the shooter during the recoil process when discharging the firearm. Be certain that your installation provides sufficient eye relief for the recoil generated by your rifle before shooting the firearm.

NOTE: Give special attention to this warning when shooting uphill and/or from a prone position. These shooting conditions can dramatically reduce eye relief. PLEASE maintain maximum eye relief when shooting heavy recoiling and/or magnum firearms. THE USER ASSUMES ALL RESPONSIBILITY AND LIABILITY FOR HAVING THE ARMASIGHT RIFLESCOPE PROPERLY MOUNTED TO A FIREARM AND USING THE ARMASIGHT RIFLESCOPE PROPERLY. ALWAYS CHECK THE CONDITION OF YOUR MOUNTING SYSTEM PRIOR TO USING YOUR FIREARM.



WARNING:

This product contains natural rubber latex, which may cause allergic reactions! The FDA has reported an increase in the number of deaths that are associated with an apparent sensitivity to natural latex proteins. If you are allergic to latex, it is a good idea to learn which products contain it and strictly avoid exposure to those products.

The information provided in this manual is for familiarization purposes only. The contents may undergo further changes with no commitment by Armasight® to notify customers of any updates.

Armasight® assumes no responsibility for any misprints or other errors that this manual may contain.

© Armasight Inc. 2015

CAUTION:

- Do not dismantle the equipment.
- Keep the equipment clean. Protect it from moisture, dramatic temperature drops, and electrical shocks.
- DO NOT force the equipment controls past their stopping points.
- DO NOT leave the equipment activated during breaks in operation.
- DO NOT store the equipment with the batteries installed.
- Thoroughly clean and dry each item before placing them into the storage case.

CAUTION:

Although the equipment is highly resistant to damage from light overload, DO NOT point it, either powered or un-powered, directly at the sun or any other source of high intensity light that the unprotected human eye cannot tolerate (such as welding arc). To prevent inadvertent exposure to these light sources, never leave the equipment unsupervised with the objective lens cap removed.

NOTES:

- To avoid losing unsaved data, DO NOT remove the batteries or disconnect the external power source while the Drone PRO is on. Power should only be removed after any changes have been saved, otherwise the unit will power up with the last saved profile.
- Inadvertent sun damage is not considered a defect in material or workmanship, and is therefore not covered in the product warranty.

LIST OF CONTENTS

TITLE	PAGE
Safety Summary	2
List of Contents	4
List of Figures	5
List of Tables	6
How to Use This Manual	6
1. INTRODUCTION	7
1.1 General Information	7
1.1.1 Type of Manual	7
1.1.2 Model Number and Equipment Name	7
1.1.3 Purpose of Equipment	7
1.1.4 Reporting Equipment Improvement Recommendations	8
1.2 Warranty Information and Registration	8
1.2.1 Warranty Information	8
1.2.2 Limitation of Liability	8
1.2.3 Product Warranty Registration	8
1.2.4 Obtaining Warranty Service	9
1.3 List of Abbreviations	10
2. DESCRIPTION AND DATA	11
2.1 System Description	11
2.2 Drone PRO Specifications	13
2.3 Standard Components	15
2.4 Optional Equipment	16
2.5 Key Features	18
3. OPERATING INSTRUCTIONS	19
3.1 Installation and Mounting	19
3.1.1 Battery Installation	19
3.1.2 Installing the Drone PRO on a Picatinny/Weaver Rail	19
3.1.3 Clamping Device Adjustment	20
3.1.4 Mounting the Platform Ring to the Drone PRO	21
3.1.5 Fastening the Advanced Wireless Remote Control to a Weapon	21
3.1.6 Installing Additional Equipment on the Drone PRO	22
3.1.7 Connecting Additional Equipment to the Drone PRO	22
3.1.8 Installing the IR Illuminator on the Drone PRO	23
3.1.9 Installing Color (Day Time) Filter to the Drone PRO	24
3.2 Controls and Display Indications	25
3.2.1 Drone PRO Controls	25
3.2.2 IR Illuminator Controls	27
3.3 Operating Procedures	28
3.3.1 Operating the Drone PRO	28
3.3.2 Bore Sighting the Drone PRO	30
3.3.3 Operating the IR Illuminator	31
3.3.4 Rangefinder Reticle	32
3.3.5 Drone PRO Shut-Down	33

4. PREVENTIVE MAINTENANCE AND TROUBLESHOOTING	34
4.1 Preventive Maintenance Checks and Services	34
4.1.1 Preventive Maintenance Checks and Services (PMCS)	34
4.2 Operator Troubleshooting	36
4.3 Maintenance	37
4.3.1 General	37
4.3.2 Cleaning Procedures	37
4.3.3 Bore Sighting	37
4.3.4 Battery Removal and Replacement	37
4.4 Return Instructions	38
APPENDIX	40
A List of Spare Parts	40
B Product Warranty Registration Card	41

LIST OF FIGURES

FIGURE	TITLE	PAGE
2-1	Drone PRO Digital Night Vision Riflescopes Appearance	11
2-2	Drone PRO Digital Night Vision Rifle. System Description	12
2-3	Drone PRO Standard Components	15
2-4	Optional Equipment	17
3-1	Battery Installation	19
3-2	Drone PRO Mount	20
3-3	Drone PRO Mount Installation	20
3-4	Platform Ring	21
3-5	Advanced Wireless Remote Control	21
3-6	Armasight Digital Recorder DT Installation	22
3-7	Video Cable	22
3-8	IR Illuminator	23
3-9	XLR-IR850 Illuminator Installation	23
3-10	XLR-IR850 Illuminator. Battery Installation	24
3-11	XLR-IR850 Illuminator with Afocal Doubler	24
3-12	Color (Day Time) Filter	24
3-13	Drone PRO Controls	25
3-14	Button Control Panel	26
3-15	IR Illuminator Controls	27
3-16	Setting Buttons	28
3-17	Reticle Patterns	29
3-18	Boresight Adjustment Buttons	31
3-19	IR Illuminator Adjustment	32
3-20	Rangefinder Reticle	32
3-21	Rangefinder Reticle Using	33
4-1	Advanced Wireless Remote Control Battery Installation	38
A-1	Drone PRO Spare Parts List	40

LIST OF TABLES

TABLE	TITLE	PAGE
2-1	Drone PRO System Description	12
2-2	System Data	13
2-3	Mechanical Data	13
2-4	Electrical Data	13
2-5	Optical Data	14
2-6	Environmental Data	14
2-7	XLR-IR850 Illuminator Data	14
2-8	Advanced Wireless Remote Control (AWREC) Data	15
2-9	Drone PRO Standard Components	15
2-10	Optional Equipment	17
3-1	Controls and Indicators	25
3-2	Button Controls	26
3-3	IR Illuminator Controls	27
3-4	Calculating Boresight Corrections	30
4-1	Preventive Maintenance Checks and Services	34
4-2	Operator Troubleshooting	36
A-1	Drone PRO Spare Parts List	40

HOW TO USE THIS MANUAL

USAGE

You must familiarize yourself with the entire manual before operating the equipment. Read the entire maintenance checklist before performing maintenance. Follow all WARNINGS, CAUTIONS, and NOTES.

MANUAL OVERVIEW

The Manual contains sections on operating and maintaining the Drone PRO Digital Night Vision Rifle-scope.

Throughout this Manual, the Drone PRO Digital Night Vision Riflescope will be referred to as the Drone PRO or the equipment.

A List of Spare Parts is in Appendix A.

The Product Warranty Registration Card is in Appendix B.

INTRODUCTION

1.1 GENERAL INFORMATION

1.1.1 TYPE OF MANUAL

Operation and Maintenance (including a List of Spare Parts).

1.1.2 MODEL NUMBER AND EQUIPMENT NAME

Drone PRO 10x Digital Night Vision Riflescope.

Drone PRO 15x Digital Night Vision Riflescope.

1.1.3 PURPOSE OF EQUIPMENT

The Drone PRO is a professional grade, Digital Night Vision rifle scope with optical 10x or 15x magnification, making it the most powerful rifle scope in its class. The Drone PRO is intended for use on a variety of hunting and sporting weapons equipped with a Picatinny/Weaver rail. Sensitive to both near-infrared and visible light, the high performance CCD imaging system of the Drone PRO provides round-the-clock and all weather target detection and discrimination. The Drone PRO is effective regardless of light conditions - in daylight, under natural lighting, at nighttime.

The Drone PRO is available in two versions, with optical magnifications of 10x and 15x.

The Drone PRO is powered by two CR123A (2x3V) batteries. The external battery power supply or 6VDC/600mA power source can also be used to power the Drone PRO.

The Drone PRO can be controlled by a wireless remote control that fastens to the weapon.

A detachable, long-range IR illuminator provides additional lighting and enables the use of the Drone PRO in extremely low light conditions or total darkness.

The Drone PRO is equipped with a standard NTSC/PAL video input/output function that makes it possible to connect to an external video monitor, or to record images for field documentation or training purposes. It also allows the transmission of data from a remote display to that of the Drone PRO.

The Drone PRO can be used in conjunction with other Armasight equipment, such as the Digital Video Recorder, External Battery Power Supply, Laser Rangefinder Module, and MCS Miniature Collimating Sight. The additional equipment can be mounted onto the Drone PRO's Picatinny/Weaver rail or detachable Platform Ring.

Extremely reliable and versatile, the Drone PRO is a valuable, multifunctional addition to any security or hunting weapon platform.

1.1.4 REPORTING EQUIPMENT IMPROVEMENT RECOMMENDATIONS

User recommendations for improvements to the device are encouraged.

Mail your comments to:

Armasight Inc.

815 Dubuque Avenue

South San Francisco, CA 94080

USA

Or, send an email to info@armasight.com.

1.2 WARRANTY INFORMATION AND REGISTRATION

1.2.1 WARRANTY INFORMATION

This product is guaranteed to be free from manufacturing defects in material and workmanship under normal use for a period of two (2) years from the date of purchase. This warranty does not cover the battery or damage caused by leaking batteries, nor does it protect against damage due to loss, misuse or mishandling.

In the event a defect that is covered by the warranty occurs during the 2 year period stated above, Armasight, at its option, will either repair or replace the product, and such action on the part of Armasight shall be the full extent of Armasight's liability, and the Customer's sole and exclusive remedy. This warranty does not cover a product (a) used in other than its normal and customary manner; (b) subjected to misuse; (c) subjected to alterations, modifications or repairs by the Customer or by any party other than Armasight without prior written consent of Armasight; (d) special order or "close-out" merchandise or merchandise sold "as-is" by either Armasight or the Armasight dealer; or (e) merchandise that has been discontinued by the manufacturer and either parts or replacement units are not available due to reasons beyond the control of Armasight. Armasight shall not be responsible for any defects or damage that in, Armasight's opinion, is a result from the mishandling, abuse, misuse, improper storage or improper operation, including use in conjunction with equipment which is electrically or mechanically incompatible with or of inferior quality to the product, as well as failure to maintain the environmental conditions specified by the manufacturer.

This warranty is extended only to the original purchaser. Any breach of this warranty shall be waived unless the customer notifies Armasight at the address noted below within the applicable warranty period.

The customer understands and agrees that except for the foregoing warranty, no other warranties written or oral, statutory, expressed or implied, including any implied warranty of merchantability or fitness for a particular purpose, shall apply to the product. All such implied warranties are hereby and expressly disclaimed.

1.2.2 LIMITATION OF LIABILITY

Armasight will not be liable for any claims, actions, suits, proceedings, costs, expenses, damages or liabilities arising out of the use of this product. Operation and use of the product are the sole responsibility of the Customer. Armasight's sole undertaking is limited to providing the products and services outlined herein in accordance with the terms and conditions of this Agreement. The provision of products sold and services performed by Armasight to the Customer shall not be interpreted, construed, or regarded, either expressly or implied, as being for the benefit of or creating any obligation toward any third party or legal entity outside Armasight and the Customer. Armasight's obligations under this Agreement extend solely to the Customer.

Armasight's liability hereunder for damages, regardless of the form or action, shall not exceed the fees or other charges paid to Armasight by the customer or customer's dealer. Armasight shall not, in any event, be liable for special, indirect, incidental, or consequential damages, including, but not limited to, lost income, lost revenue, or lost profit, whether such damages were foreseeable or not at the time of purchase, and whether or not such damages arise out of a breach of warranty, a breach of agreement, negligence, strict liability or any other theory of liability.

1.2.3 PRODUCT WARRANTY REGISTRATION

In order to validate the warranty on your product, Armasight must receive a completed Product Warranty Registration Card for each unit, or the Customer can complete a warranty registration on our website at www.armsight.com. Please complete the included form (Appendix B) and immediately mail it to our Service Center:

Armasight Inc.
815 Dubuque Avenue
South San Francisco, CA 94080
USA

1.2.4 OBTAINING WARRANTY SERVICE

To obtain warranty service on your unit, the End-User must notify the Armasight's service department in order to receive a Return Merchandise Authorization number (RMA#). The customer can do this by sending an email to service@armsight.com.

When returning any product, please take or send the product, postage paid, with a copy of your sales receipt, to our service center, Armasight Inc. at the address noted above. All merchandise must be fully insured with the correct postage; Armasight will not be responsible for improper postage or missing or damaged merchandise during shipment.

When sending merchandise back, please write the RMA# clearly on the outside of the shipping box. Please include a letter that indicates your RMA#, Name, Return Address, reason for service return, Contact information (such as a valid telephone number and/or e-mail address), as well as proof of your purchases that will help us to establish the valid start date of the warranty. Product merchandise returns that do not have an RMA listed may be refused or be subject to a significant delay in processing.

Estimated Warranty service time is 10-20 business days. The End-User/ Customer is responsible for postage to Armasight for any warranty service. Armasight will cover return postage/shipping to continental USA End-Users/ Customers after warranty repair only if product is covered by the aforementioned warranty. Armasight will return the product after warranty service via domestic ground service and/or domestic mail. The postage and shipping fees for any other requested, required or international shipping methods will be the responsibility of the End-User/ Customer.

1.3 LIST OF ABBREVIATIONS

µm	micrometer
AWREC	Advanced Wireless Remote Control
C	Celsius (Centigrade)
CCW	counterclockwise
CW	clockwise
F	Fahrenheit
FL	Focal Length
g	gram
H	Height
hr	hour
in	inch
inf.	infinity
kg	kilogram
L	Length
lbs	pounds
m	meter
mA	milliampere
mil	angular mil
min	minute
mm	millimeter
MOA	Minute Of Angle
mrad	milliradian
NO.	Number
NTSC	National Television Standards Committee
oz	ounce
PAL	Phase Alternating Line
PMCS	Preventive Maintenance Checks and Services
RMA#	Return Merchandise Authorization number
sec	second
SEQ	sequence
SOA	Second Of Angle
SR	Service Representative
V	Volt
W	Width

DESCRIPTION AND DATA

2.1 SYSTEM DESCRIPTION

The Drone PRO consists of two primary parts: a CCD imaging aiming device and a mount. The equipment comes as shown in Figure 2-1, with the mount secured to the body of the device.

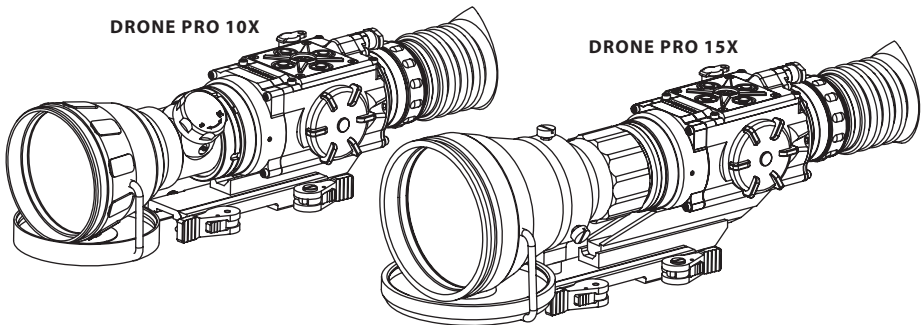

FIGURE 2-1. DRONE PRO DIGITAL NIGHT VISION RIFLESCOPES APPEARANCE

The Drone PRO is a highly light-sensitive device equipped with an aiming reticle. The Drone PRO sensor (CCD array) reacts to near-infrared and visible light and converts the received light into electric charges. The controlling circuit converts the entire contents of the two-dimensional array to a sequence of voltages that are processed into a continuous analog signal. The Drone PRO displays, as a result, a real-time contrast grayscale images corresponding to the scene projected onto the focal plane of the sensor. The reticle is digitally inputted in the display, which is in the image plane.

The professional line of Armasight night vision digital devices can be used in all lighting conditions, at any time of the day. They are equipped with high-tech color CCD sensors and color displays with high resolution, which allow the achievement of a superior quality color image. Digital devices are also equipped with an automatic system to switch between day and night modes of observation. The image will appear in color in daytime use, under bright artificial light. When the illumination is reduced below a certain level the unit switches to night mode with a black-and-white image. This increases the level of sensitivity of the device and reduces the noise in the image.

The main optical-electronic components of the Drone PRO include: an objective lens, an eyepiece, a grayscale CCD camera, a display, a control card, and a button control panel.

The Drone PRO is equipped with a manually adjustable eyepiece and focusable objective lens, and digital boresight adjustment.

To accommodate individual user needs, the Drone PRO has a variety of digitally controlled options, including customizable display brightness, reticle pattern, and reticle color.

Information on the current operating state (battery status, reticle running coordinate, etc.) is continuously displayed, making field operation of the Drone PRO simple and convenient.

Manufactured for exceptional durability, the Drone PRO has a lightweight and robust aluminum body. A side Picatinny/Weaver rail allows for the installation of an optional video recorder, extended battery pack, IR illuminator, laser rangefinder module, or other equipment.

A detachable Platform Ring makes it possible to mount additional equipment to the top of the device, such as an IR illuminator or Armasight MCS Miniature Collimating Sight.

A detachable, long-range IR illuminator provides additional lighting and enables the use of the Drone PRO in extremely low light conditions or total darkness.

A standard NTSC/PAL video input/output connector enables an external video display (monitor, TV) or video recorder to be connected to the Drone PRO. An external 6 VDC/600mA power source can also be connected to the Drone PRO.

The quick-release mount of the Drone PRO fits any Picatinny, MIL-STD-1913, or Weaver weapon rail. The mount's lever-cam clamping device ensures easy, quick, and reliable mounting and removal.

The Drone PRO is powered by two CR123A (2x3V) batteries. The external battery power supply or 6VDC/600mA power source can also be used to power the Drone PRO.

The Drone PRO is shown in Figure 2-2. The ITEM NO. column of Table 2-1 indicates the number used to identify items in Figure 2-2.

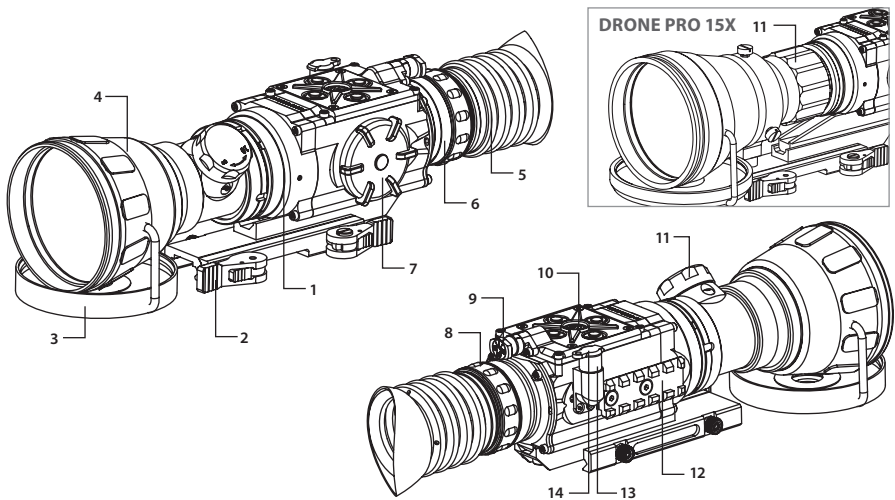

FIGURE 2-2. DRONE PRO DIGITAL NIGHT VISION RIFLESCOPE. SYSTEM DESCRIPTION

TABLE 2-1. DRONE PRO SYSTEM DESCRIPTION

ITEM	DESCRIPTION	ITEM	DESCRIPTION
1	Body	8	Eyepiece Focus Ring
2	Mount	9	Turn-pull Switch
3	Objective Lens Cap	10	Button Control Panel
4	Objective Lens	11	Objective Focus Knob (Ring)
5	Eyecup	12	Side Picatinny/Weaver Rail
6	Eyepiece	13	Connector
7	Battery Cap	14	Connector Cap

2.2 DRONE PRO SPECIFICATIONS

TABLE 2-2. SYSTEM DATA

ITEM	DRONE PRO 10X	DRONE PRO 15X
CCD Camera	High-rate High Resolution Near-IR Hypersensitive CCD Camera	
Pixel CCD Array Format	976×582	
CCD Array Spectral Response	0.4 to 1.1 μm	
Display Type	AMOLED SVGA 060	
Pixel Display Format	800×600	
Display Brightness	Discretely Adjustable to 8 Levels	
Turn-on Time, max	3 sec	
Reticle Type	7-Pattern Digitally Controlled: “Dot”/ “Small Crosshair”/ “Big Crosshair”/ “Crosshair with Dot”/ “Circle”/ “Rangefinder Reticle”/ “No Reticle”	
Reticle Color	Black / White	
Windage/ Elevation Boresight Adjustment Type	Digitally Controlled	
Windage/ Elevation Boresight Increment	0.42 MOA (25 SOA) 0.12 Mils 1.2cm / 100m 0.44in / 100yd	0.3 MOA 0.09 Mils 0.9 cm / 100 m 0.32 in / 100 yd
Boresight Adjustment Range	±55 MOA Horizontal ±30 MOA Vertical	±40 MOA Horizontal ±22 MOA Vertical
Analog Input Format	PAL/ NTSC	
Analog Output Format	PAL	
PAL Output Resolution	768×574 pixels	

TABLE 2-3. MECHANICAL DATA

ITEM	DRONE PRO 10X	DRONE PRO 15X
Weapon Mount Type	Picatinny, MIL-STD-1913, or Weaver Rails	
Height of the Drone PRO Axis above Picatinny/Weaver Rail	42 mm (1.65 in)	
Overall Dimensions	260×76×85 mm (10.2×3.0×3.4 in)	290×91×107 mm (14.4×3.6×4.2 in)
Weight (w/o Batteries)	1.02 kg (2.2 lbs)	1.3 kg (2.87 lbs)

TABLE 2-4. ELECTRICAL DATA

ITEM	DATA
Battery	Two CR123A 3V Lithium batteries or CR123 type rechargeable batteries with voltage from 3.0V to 3.7V (2)*
Current Consumption, maximum	450 mA
Battery Life at 20°C (68°F)	up to 3 (optional up to 10 hrs)
External Power Supply	Optional Extended Battery Pack with rechargeable batteries (up to 7 hours) or 6 VDC/ 600mA external power source

* Rechargeable batteries with voltage 3.2V-3.7V can be used only in devices with serial number starting from 140885

TABLE 2-5. OPTICAL DATA

ITEM	DRONE PRO 10X	DRONE PRO 15X
Magnification	10x	15x
Field of View	- ang. X degrees	2.6°
	- ang. Y degrees	2.0°
Objective Focal Length	108mm	145mm
Objective F-number	1:1.54	1:1.8
Exit Pupil Diameter	10 mm	
Eye Relief	45 mm	
Focus Method	Manual	
Focusing Range	10m to infinity	
Diopter Adjustment	Manual	
Diopter Adjustment Range	±5 diopter	

TABLE 2-6. ENVIRONMENTAL DATA

ITEM	DATA
Operating Temperature	-40 to +50°C (-40 to +122°F)
Storage Temperature	-50 to +70°C (-58 to +158°F)
Recoil Resistance	700g
Environmental Rating	Water and Fog Resistant

TABLE 2-7. XLR-IR850 ILLUMINATOR DATA

ITEM	DATA
IR Emitter Type	LED
Power	1000 mW
Peak Wavelength	850 nm
Illumination Range	up to 1000 m
Divergence	4 to 35°
Battery	Single 18650 Rechargeable Battery (3.7V) *
Battery Life at 20 °C (68 °F)	up to 10 hr (1/4 Power); 8 hr (1/2 Power); 6 hr (3/4 Power); 2.5 hr (Full Power)
Overall Dimensions (with Mount)	150×48×57 mm (5.9×1.9×2.2 in)
Weight (with Mount, w/o Battery)	264 g (9.3 oz)
Operating Temperature	-20 to +50°C (-4 to 122°F)
Storage Temperature	-50 to +70°C (-58 to 158°F)
Environmental Rating	Water Resistant

* 18650 rechargeable battery and charger are included

TABLE 2-8. ADVANCED WIRELESS REMOTE CONTROL (AWREC) DATA

ITEM	DATA
Type	Wireless Remote Control
Working Range	up to 0.5m
Battery	Single CR2032 Lithium battery (3V)
Battery Life at 20 °C (68 °F)	Approx. 10,000 clicks
Overall Dimensions	48x39x18 mm (1.9x1.5x0.7 in)
Weight (with Battery)	25 g (0.9 oz)
Operating Temperature	-30 to +50°C (-22 to 122°F)
Storage Temperature	-50 to +70°C (-58 to 158°F)
Environmental Rating	Water and Fog Resistant

2.3 STANDARD COMPONENTS

The Drone PRO standard components are shown in Figure 2-3 and listed in Table 2-9. The ITEM NO. column indicates the number used to identify items in Figure 2-3.

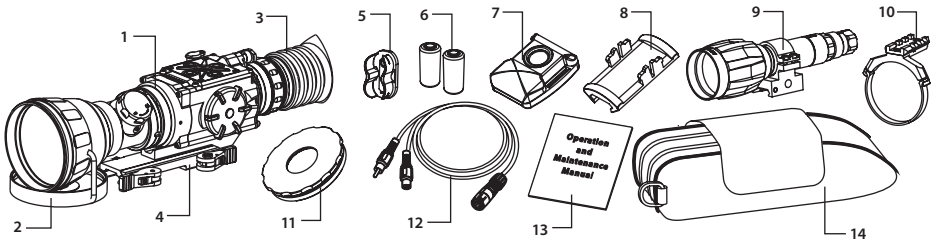

FIGURE 2-3. DRONE PRO STANDARD COMPONENT

TABLE 2-9. DRONE PRO STANDARD COMPONENTS

ITEM NO.	DESCRIPTION	QUANTITY
1	Armasight Drone PRO Digital Night Vision Riflescope A Digital Night Vision aiming device. Comes fully assembled with a quick-release Picatinny/Weaver mount.	1
2	Objective Lens Cap Protects the objective lens from dirt and mechanical damage, and provides protection from light overload. Comes attached to the objective lens.	1
3	Eye-cup A rubber cup used to protect the eyepiece as well as provide comfort for the operator. Comes attached to the eyepiece.	1
4	Mount A double lever-lock quick release mount used to install the Drone PRO on a Picatinny/Weaver rail. Comes attached to the Drone PRO.	1

TABLE 2-9. CONTINUED

ITEM NO.	DESCRIPTION	QUANTITY
5	Battery Cassette Intended for the installation of two CR123 batteries in the battery compartment. The Drone PRO comes with two battery cassettes (includes one installed in the battery compartment and one spare cassette).	2
6	CR123A Lithium Battery Batteries are used to power the Drone PRO.	2
7	Advanced Wireless Remote Control (AWREC) Allows the user to operate the Drone PRO in remote activation mode. Ensures quick and silent activation/deactivation of the equipment. Comes with CR2032 (3V) battery installed.	1
8	Picatinny Adapter for Advanced Wireless Remote Control Allows the advanced wireless remote control to be installed on a weapon's Picatinny/Weaver rail.	1
9	XLR-IR850 Detachable Wide Angle Adjustable X-Long-Range Infrared Illuminator A detachable LED long-range infrared illuminator with a wide, adjustable beam angle. Compatible with night vision devices that rely on CCD or image intensifier technology. Should be used when there is little to no ambient light. Comes fully assembled with a dedicated mount in order to be installed on a Picatinny/Weaver rail. The Riser for XLR-IR (10 mm) #182, 18650 rechargeable battery, and Charger are included.	1
10	Platform Ring A dedicated mount with a Picatinny/Weaver rail, used to install the additional equipment on the Drone PRO, such as the Armasight MCS Miniature Collimating Sight.	1
11	Color (Day Time) Filter Optical filter which was purposely designed to improve color rendering of digital devices, when they are used in color mode during daylight hours.	1
12	Video Cable A cable used to connect the analog video input/output of the Drone PRO to external display devices (a monitor, TV) or power sources.	1
13	Operation and Maintenance Manual Provides safety information, equipment description, mounting procedures, operating instructions, and preventive maintenance checks and services (including a List of Spare Parts).	1
14	Carrying Case A textile bag used for the transportation and storage of the Drone PRO and its accessories.	1

2.4 OPTIONAL EQUIPMENT

Optional items are shown in Figure 2-4 and listed in Table 2-10.

The ITEM NO. column indicates the number used to identify items in Figure 2-4.

The PART NO. column indicates the primary number used by the manufacturer, to identify an item.

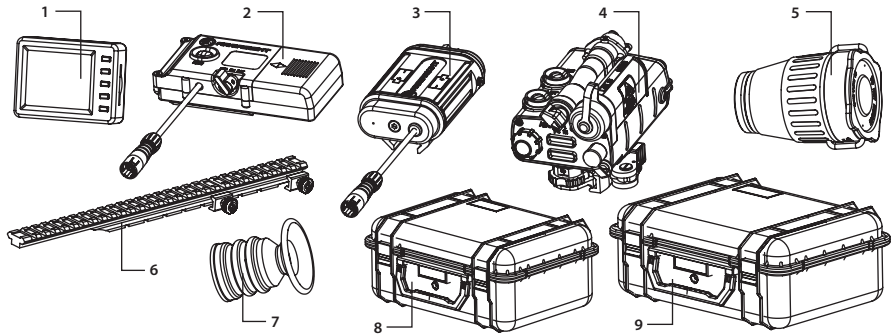

FIGURE 2-4. OPTIONAL EQUIPMENT

TABLE 2-10. OPTIONAL EQUIPMENT

ITEM NO.	DESCRIPTION	PART NO.
1	HD DVR Digital Video Recorder High Definition Digital Recorder for all Armasight High Performance Digital and Thermal Devices.	ATAM000005
2	Digital Video Recorder DT A compact digital video recorder used for video recording, storage and play-back. Can also serve as an external power source. Equipped with a remote control.	ATAM000004
3	External Battery Power Supply The power source for extended operational time. Takes four CR123A Lithium batteries (3V) or CR123 type rechargeable batteries (3.2V or 3.7V) or two 18650 type rechargeable batteries (3.7V).	ATAM000008
4	AMRF2200 Advanced Modular Range Finder Module of a rangefinder is designed to determine the exact distance between the observer and the target. The measurement results are shown on the displays of module and in the field of view of the connected digital device.	IALA00AMRF22001
5	XLR-IR Afocal Doubler Doubles the distance of XLR-IR850 IR Illuminator beam. Comes complete with an thread adapter #174.	ANAF18XXLR
6	Extended Rail Adapter #85 Dovetail Weaver Picatinny Rail Adapter Extends 7.5 " to 11.5" Tactical Scope Mount.	ANAM000045
7	Shutter Eyeguard A specially designed latex eyecup that reduces the amount of light that escapes from the eyepiece and prevents illumination of the user's face, minimizing the risk of detection. Prevents ambient light from entering the equipment.	ANEC000010
8	Hard Shipping/Storage Case #101 A protective case used for the shipping/storage of the Drone PRO and its accessories.	ANHC000001
9	Hard Shipping/Storage Case #102 A protective case used for the shipping/storage of the Drone PRO and its accessories.	ANHC000004

2.5 KEY FEATURES

- 10x or 15x optical magnification
- High-performance CCD camera
- Bright-light tolerance
- Lightweight and robust design
- Easy to operate
- Manually adjustable eyepiece and objective lens
- Real-time display
- Digitally controlled features:
 - Adjustable display brightness
 - Selectable 7-pattern reticle, including a “no reticle” option
 - Reticle color inversion (Black/White)
 - Windage/Elevation bore sighting
- Current operational state information display (battery status, active function etc.)
- Wireless remote control
- Analog video input (NTSC/PAL) and output (PAL)
- Powered by two standard CR123A batteries or CR123 type rechargeable batteries (max 3.7 volts each)
- Power input capability
- Digital video recorder (optional)
- Fits any Picatinny, MIL-STD-1913, and Weaver rail with an adjustable quick-release mount
- Serviceability under severe conditions
- Heavily water-resistant
- Limited two-year warranty

OPERATING INSTRUCTIONS

3.1 INSTALLATION AND MOUNTING

3.1.1 BATTERY INSTALLATION

CAUTION:

Before installing a battery, verify that the equipment is off.

Install two CR123A batteries as follows (refer to Figure 3-1):

1. Unscrew the battery cap (A).
2. Remove the battery cassette (B).
3. Insert the batteries (C) into cassette. Align the polarity symbols on the batteries with the polarity symbols on the cassette.
4. Insert the cassette with installed batteries to place.
5. Replace the battery cap.

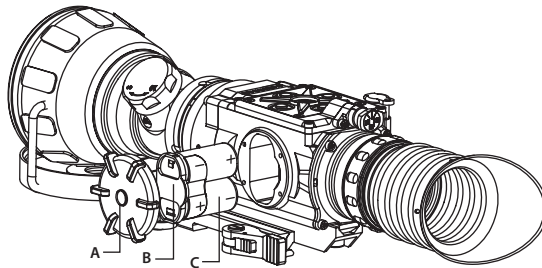

FIGURE 3-1. BATTERY INSTALLATION

3.1.2 INSTALLING THE DRONE PRO ON A PICATINNY/WEAVER RAIL

**WARNING:**

Always make sure your firearm is unloaded before you place the scope on the firearm. Reconfirm that the chamber is empty if you stop the procedure then resume later. Safe handling rules should be followed at all times.

The Drone PRO comes fully-assembled with a Picatinny/Weaver mount.

The mount (A, Figure 3-3) is attached to the Drone PRO seating rail (C) with two M5×8 flathead socket cap screws (B).

To install the Drone PRO on a Picatinny/ Weaver rail, perform the following:

1. Unlock the clamping device of the Drone PRO mount by pushing down on the lever holders (A, Figure 3-2) and unlocking the levers (B, Figure 3-2).
2. Install the Drone PRO on the Picatinny/ Weaver rail so that the stops (C, see Figure 3-2) slide into the transverse slots on the rail.
3. Affix the Drone PRO to the rail by locking the levers (B, Figure 3-2).
4. Verify that the clamping device is firmly holding the Drone PRO. If necessary, adjust the clamping device's lever-cam locks as detailed in Part 3.1.3 (Clamping Device Adjustment).

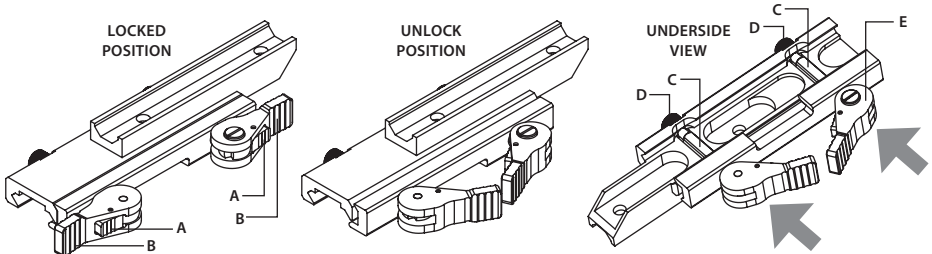

FIGURE 3-2. DRONE PRO MOUNT

To provide you with greater flexibility in mounting Drone PRO weapon sight on the weapon, the dual lever mount can be installed in two different positions. On the bottom of the Drone PRO body there are two pairs of threaded mounting holes in the seating rail. You can shift the mounting position of your Drone PRO by an extra 1.5 inches backwards.

To change the position of Drone PRO mount, please follow the instructions below:

1. Remove the two screws (B, Figure 3-3) that attach the mount (A, Figure 3-3) to the seating rail (C, Figure 3-3).
2. Remove the mount.
3. Change the position of the mount.
4. Install the two screws into the mount and tight up the screws.

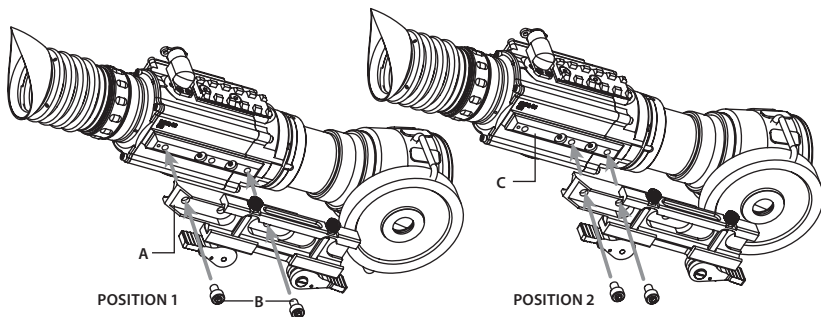

FIGURE 3-3. THE DRONE PRO MOUNT INSTALLATION

3.1.3 CLAMPING DEVICE ADJUSTMENT

To adjust the mount's clamping device, do the following:

1. Remove the Drone PRO from the weapon.
2. With the clamping device unlocked (as shown in Figure 3-2), push the cam (E) towards the arrow, which will cause the nut (D) to slide out of its hole.

- To tighten/ loosen the clamping device, push down on the cam (E) and turn the nut (D) CW/ CCW respectively, in one-two increments (see note below). Much like when the cam (E) is released, backward-moving springs will cause the nut (D) to slide back into its hole.

NOTE:

The eight-sided nuts of the mount lever-cam locks will only fit into their holes if turned in one of the discrete positions, using increments equal to $360^{\circ}/8$.

- Verify that the adjusted lever-cam lock securely holds the weapon mounting rail.
- Repeat the procedure to adjust the clamping device's second lever-cam lock.

3.1.4 MOUNTING THE PLATFORM RING TO THE DRONE PRO

Mount the Platform Ring on the Drone PRO as follows (refer to Figure 3-4):

- Using a 1.5 hex key, unscrew the both clamp screws (A).
- Place the clamps (B, C) onto the mounting tube. Screw the clamps together without tightening the screws (A).
- Adjust position of the Platform Ring until its rail (D) is level. Apply a small amount of thread lock to the threads and tighten the screws (A).

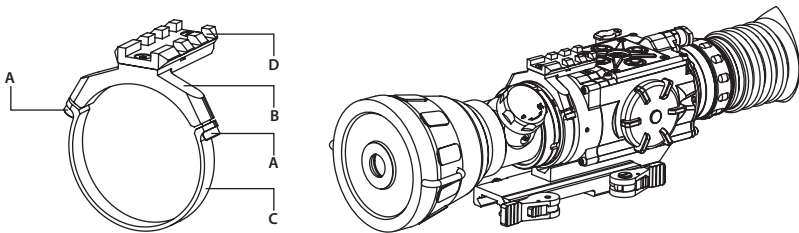

FIGURE 3-4. PLATFORM RING

3.1.5 FASTENING THE ADVANCED WIRELESS REMOTE CONTROL TO A WEAPON

Using Velcro tape (A, Figure 3-5), fasten the remote control (B) to your weapon in an easily accessible place (e.g., on the front of the rifle stock).

If your rifle has a Picatinny or Weaver rail on the front end, you can use the Picatinny Adapter for the Advanced Wireless Remote (C). Install the adapter onto the rail (D). Insert the remote control unit into the adapter.

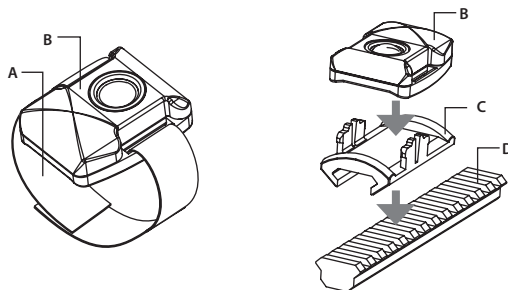

FIGURE 3-5. ADVANCED WIRELESS REMOTE CONTROL

3.1.6 INSTALLING ADDITIONAL EQUIPMENT ON THE DRONE PRO

Use the Platform Ring to install any additional equipment, such as the Armasight MCS Miniature Collimating Sight. For adapter mounting procedures, see Part 3.1.4.

Use the side Picatinny/Weaver rail to install any additional equipment, such as a digital video recorder, a laser rangefinder, or an external battery power supply.

3.1.7 CONNECTING AN ADDITIONAL EQUIPMENT TO THE DRONE PRO

CAUTION:

Turn off the Drone PRO before you begin connecting/disconnecting any external equipment and before removing the batteries.

Connect a cable of digital video recorder, an external battery power supply, or laser rangefinder module to the Drone PRO connector.

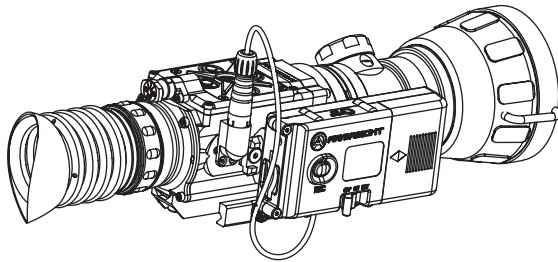

FIGURE 3-6. ARMASIGHT DIGITAL RECORDER DT INSTALLATION

Use the plug A (Figure 3-7) of the video cable to connect an external video recorder, monitor, or TV to the Drone PRO connector.

Use the plug B of the video cable to connect an external power source (6 VDC/600mA) to the Drone PRO connector. The external power supply must have a standard 6mm OD double-pole socket with a positive center contact.

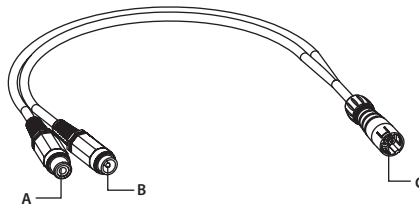

FIGURE 3-7. VIDEO CABLE

NOTE:

The external power supply must have a standard OD double-pole socket with a positive center contact.

CAUTION:

After removing the cable, replace the protective cap over the connector.

3.1.8 INSTALLING THE IR ILLUMINATOR ON THE DRONE PRO

Armasight long range IR illuminators are delivered with a dedicated mount, to be installed on the Picatinny/Weaver rail.

To mount an IR illuminator on the Drone PRO, do the following (refer to Figure 3-8):

1. With the nut (A) loosened, install the mount (B) on the rail of riser (E) so that the stop (C) slides into one of the transverse slots of the rail.
2. Tighten the nut (A).

NOTE:

The mount clamp (D) has a spherical hinge that allows the IR illuminator to be aligned with the field of view of the Drone Pro for maximum effectiveness.

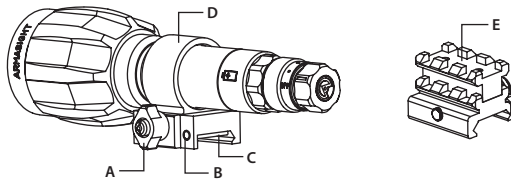

FIGURE 3-8. IR ILLUMINATOR

3. With the nut of riser (Figure 3-9, A) loosened, install the illuminator on the Weaver rail so that the recoil stop of riser slides into one of the transverse slots of the rail.
4. Tighten the nut of riser (A).

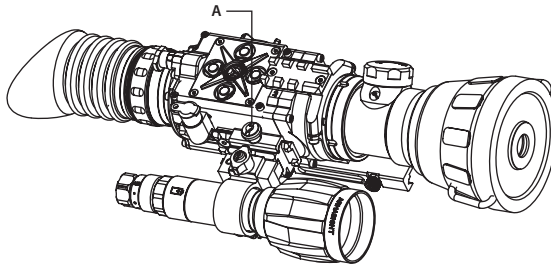

FIGURE 3-9. XLR-IR850 ILLUMINATOR INSTALLATION

Fully charge the 18650 rechargeable battery before installing. Insert the battery into charger, aligning the polarity symbols on the battery with the polarity symbols on the charger. Never install the battery backwards.

Connect the power cord to an appropriate power source. An indicator light will flash red when a battery is charging, and will change to green when battery has been fully charged. Remove the battery promptly after charging has been completed.

Install the battery as follows (refer to Figure 3-10):

CAUTION:

Ensure that the IR Illuminator is off before installing the battery.

1. Unscrew the battery cap (A).
2. Install the 18650 rechargeable battery (B) into the battery compartment. Align the polarity symbols on the battery with those on the cap face.

3. Replace the battery cap (A).

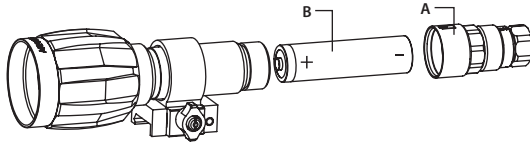

FIGURE 3-10. XLR-IR850 ILLUMINATOR. BATTERY INSTALLATION

The XLR-IR850 can be used as hand-held long-range IR illuminator with optional Afocal Doubler. Attach the magnifying lens to the XLR-IR850 as follows (refer to Figure 3-11):

1. Screw the Afocal Doubler (A) into the threading adapter (B).
2. Screw the Afocal Doubler with adapter into the threading of the XLR-IR850 objective lens (C) housing. Be careful not to over-tighten the lens.

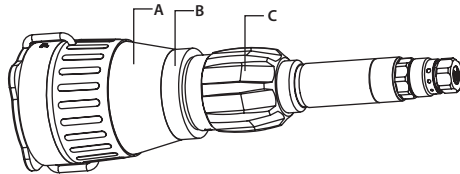

FIGURE 3-11. XLR-IR850 ILLUMINATOR WITH AFOCAL DOUBLER

NOTE:

The caution notice DO NOT REMOVE IN DAYLIGHT on the front lens cap of this universal magnifying lens is not applicable when using it on the XLR-IR850.

3.1.9 INSTALLING COLOR (DAY TIME) FILTER TO THE DRONE PRO

The Color (Day Time) filter (Figure 3-12, A) is designed to improve color reproduction when using digital devices during daylight.

To install the filter, screw it into the thread in front of the objective lens (Figure 3-12, B) of the digital device.

NOTE:

The Color filter partially cuts off infrared emission. Therefore it is recommended to remove the filter when the equipment is used at dark.

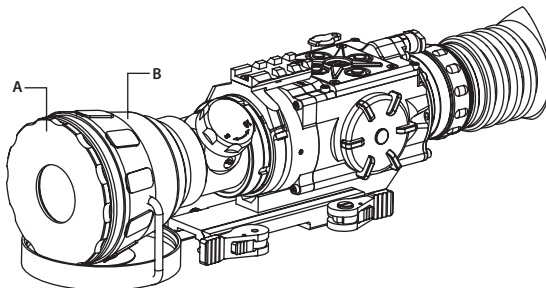

FIGURE 3-12. COLOR (DAY TIME) FILTER

3.2 CONTROLS AND DISPLAY INDICATIONS

3.2.1 DRONE PRO CONTROLS

CAUTION:

DO NOT force the equipment controls past their stopping points.

The Drone PRO controls are shown in Figures 3-13 and 3-14, and are defined in Tables 3-1 and 3-2. The ITEM NO. columns of the tables indicate the numbers used to identify items in the figures.

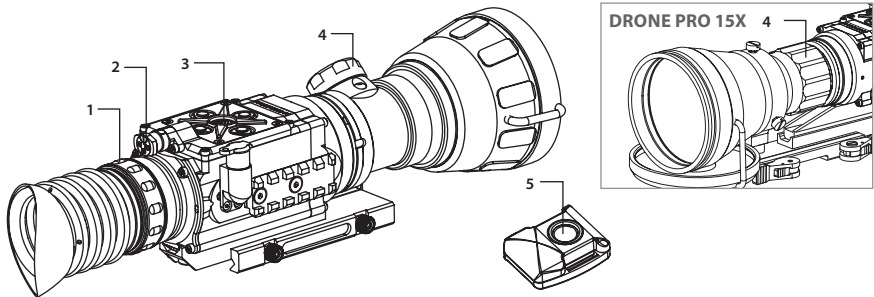

FIGURE 3-13. DRONE PRO CONTROLS

TABLE 3-1. CONTROLS AND INDICATORS

ITEM NO.	CONTROL/INDICATOR	FUNCTION
1	Eyepiece Focus Ring	Adjusts the eyepiece diopter. The total diopter adjustment range is covered with 2 turns of the ring.
2	Turn-Pull Switch	Activates the Drone PRO when turned to ON. NOTE: You must pull the knob before turning in order to activate either ON or STB. Activates Standby Mode when turned to STB. Deactivates the Drone PRO when turned to OFF.
3	Control Panel Buttons	Configures operational settings. See Table 3-2 for button functions.
4	Objective Focus Knob (Drone PRO 10x) / Objective Focus Ring (Drone PRO 15x)	Focuses the objective lens. Adjusts for sharpest view of the scene.
5	Remote Control Button	Activates/ deactivates the Drone PRO in Standby Mode. To turn the unit on, press button once, to turn it off – press button again.
—	Battery Status Indicator (a battery icon in the lower right-hand of the display)*	The light gray bar in the battery icon indicates the current power level of the internal battery, or remaining battery life. A totally shaded battery icon indicates the fully charged battery. A flashing transparent battery icon indicates a low battery.

* The Battery Status Indicator not show a correct power level when the external battery or power supply is used.

NOTE:

Various display symbols indicating the current operating state of the Drone PRO can be displayed permanently, may appear momentarily, or can be set to appear only when a certain function is activated.

The Drone PRO button control panel is shown in Figures 3-14.

Table 3-2 contains the button functions and their brief descriptions. The ITEM NO. column of the table indicates the number used to identify buttons in Figure 3-14.

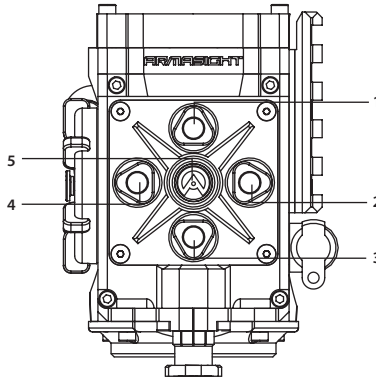

FIGURE 3-14. BUTTON CONTROL PANEL

NOTE:

Each button is responsible for some functions selected by briefly pushing or holding down the button, or using the button in combination with a second one (as described in Table 3-2). Pushing a button for 3+ seconds is considered “holding down.”

TABLE 3-2. BUTTON CONTROLS

ITEM NO.	FUNCTION	DESCRIPTION
1, 3	DISPLAY BRIGHTNESS CONTROL	One quick push of the button (1) will increase the screen brightness; push the button (3) to decrease the screen brightness. NOTE: It takes seven steps to go from the darkest to the brightest level, for a total of eight levels.
	RESET TO ZERO AZIMUTH AND ELEVATION	Push and hold down the buttons (1) and (3) at the same time to bring the reticle in the display center. The ZERO indication will appear in the display (meaning x-y co-ordinates set to “Zero” value i.e. the reticle is central in the screen).
2	INVERTS RETICLE COLOR	Quickly push the button (2) to invert the reticle (switch between black and white reticles). Save your preference by pushing and hold down buttons (2)and(4) simultaneously. SAVE should appear in the bottom left corner of the display.
2, 4	SAVE THE OPTIONS	To save your preference, push and holding down buttons (2) and (4) simultaneously. SAVE should appear in the bottom left corner of the display.

TABLE 3-2. CONTINUED

ITEM NO.	FUNCTION	DESCRIPTION
4	RETICLE PATTERNS CONTROL	<p>Quickly push the button (4) to switch between available reticle patterns: "Dot", "Small Crosshair", "Big Crosshair", "Crosshair with Dot", "Circle", "Rangefinder Reticle", or "No Reticle".</p> <p>To save your preference, push and hold down buttons (2) and (4) simultaneously. SAVE should appear in the bottom left corner of the display.</p>
5	BORESIGHT ADJUSTMENT (uses in combination with other buttons)	<p>Push and hold down the button (5) to display the coordinates of the reticle center. The coordinates will be indicated in the lower left-hand corner of the display.*</p> <p>While holding down the button (5), push the buttons:</p> <ul style="list-style-type: none"> - (3)/(1) to shift the reticle in the display up/down, - (4)/(2) to shift the reticle to the right/left, respectively. <p>To reset to zero azimuth and elevation, push the combination of buttons (1+3). The reticle will shift in the display center. The ZERO indication will appear in the bottom left corner of the display.</p> <p>After completing your customization, save your preference by pushing and holding buttons (2) and (4) simultaneously. SAVE should appear in the bottom left corner of the display.</p>

* This feature is available only in devices with serial number starting from 150028

3.2.2 IR ILLUMINATOR CONTROLS

The controls of the optional IR illuminators are shown in Figure 3-15 and defined in Table 3-3. The ITEM NO. column indicates the number used to identify items in Figure 3-15.

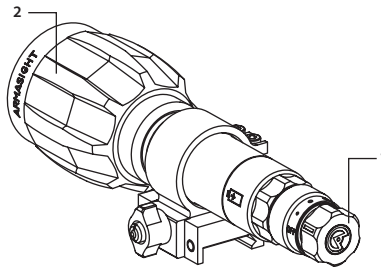

FIGURE 3-15. IR ILLUMINATOR CONTROLS

TABLE 3-3. IR ILLUMINATOR CONTROLS

ITEM NO.	FUNCTION	DESCRIPTION
1	POWER SWITCH	<p>Switches the IR illuminator on/off and adjusts for radiated power. Four ON positions are located between the two OFF positions, and are each marked with a different-sized spot. The larger the spot, the greater the radiated power.</p>
2	LENS FOCUS	<p>Adjusts for IR beam divergence. Adjustment range is covered within approximately one turn of the lens.</p>

3.3 OPERATING PROCEDURES

3.3.1 OPERATING THE DRONE PRO



WARNING:

Always make sure your firearm is unloaded before you place the scope on the firearm. Reconfirm that the chamber is empty if you stop the procedure then resume later. Safe handling rules should be followed at all times.

CAUTION:

DO NOT force the equipment controls past their stopping points.

CAUTION:

Although the Drone PRO is highly resistant to damage from light overload, DO NOT point it, either powered or un-powered, directly at the sun or any other source of high intensity light that the unprotected human eye cannot tolerate (such as welding arc). To prevent exposure to these types of sources, never leave the equipment unsupervised with the objective lens cap removed.

Operating procedures are as follows:

1. Remove the Drone PRO from the carrying case.
2. Install the Drone PRO on the weapon's Picatinny/Weaver rail.
3. Verify that the Drone PRO is securely mounted to the weapon.
4. Remove the objective lens cap.
5. Point the equipment at an object.
6. Activate the Drone PRO by turning the turn-pull switch to the ON position. After approximately 3 sec, video of the scene should appear.

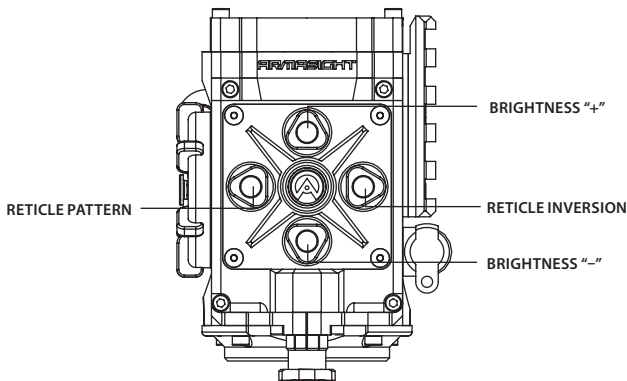

FIGURE 3-16. SETTING BUTTONS

7. Adjust the Drone PRO for your eyesight by turning the eyepiece focus rings CW up to the stop, and then CCW until the display and symbols (such as the reticle) are as clear as possible. Bring the object into focus by turning the objective focus knob ring (ring).

NOTE:

The total diopter adjustment range is covered with 2 turns of the eyepiece focus ring.
The total focus range is covered with 3/4 turn of the objective focus knob (ring).

8. Using the buttons on the control panel (Figure 3-16), configure the Drone PRO to adapt it to your situation.

For more information on operational setting procedures, see Part 3.2 (Controls and Display Indications).

A. Adjust the brightness of the display for your comfort.

Momentarily push the brightness adjustment buttons to increase/decrease the display brightness by one level at a time until you reach your desired brightness level.

B. Select a reticle pattern

Short push the reticle pattern switch button the necessary number of times to select from a choice of reticle patterns: "Dot", "Small Crosshair", "Big Crosshair", "Crosshair with Dot", "Circle", "Rangefinder Reticle", or "No Reticle" (Figure 3-17).

NOTE:

The reticles appear in the most recently saved position in the display.

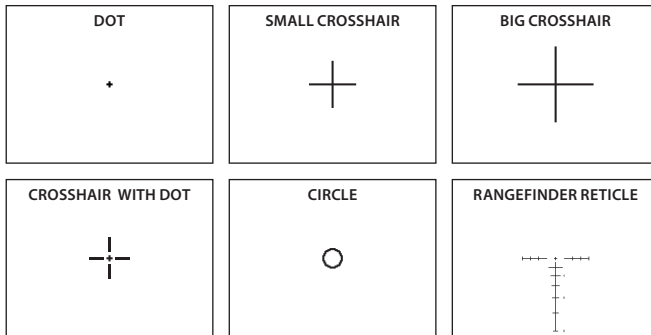

FIGURE 3-17. RETICLE PATTERNS

C. Invert the reticle color.

Momentarily push the reticle inversion button to switch between black and white reticles.

D. After configuration is complete, save your settings by pushing the "save" combination of buttons (see Table 3.2), and holding the buttons until the word "SAVE" appears in the bottom left hand corner of the screen.

9. To align the barrel of the weapon, place the reticle on the desired target. To allow for the bullet travel (i.e. bullet drop, windage, and the target mobility), use the boresight adjustment buttons.
10. To operate the Drone PRO with Advanced Wireless Remote Control (AWREC), turn the function switch to the STB position (Standby Mode). After it the Remote Control button can activate/ deactivate the device in two ways:
- 1) To turn the device on, press the remote control button once, to turn it off – press the button again.
 - 2) To operate the device in short-time activation mode (see note below), press and hold the remote control button down for 1.5+ seconds. Release the remote control button to deactivate the device.

NOTE:

Devices manufactured before 2016 do not have the short-time activation mode.

CAUTION:

DO NOT leave the equipment activated when it is not in use.

3.3.2 BORE SIGHTING THE DRONE PRO**WARNING:**

Always make sure your firearm is unloaded before you place the scope on the firearm. Reconfirm that the chamber is empty if you stop the procedure then resume later. Safe handling rules should be followed at all times.

Boresight the Drone PRO as follows:

1. Sight onto a target at a suitable zeroing range (typically 60-100 metres, depending on caliber).
2. Turn on the Drone PRO.
3. Adjust the eyepiece and focus the objective lens to sharpest image of the target.
4. Adjust the brightness of the display.
5. Select a reticle pattern.
6. Take aim by centering the reticle on the target and firing a series of shots (3-4).
7. Find the center of impact and measure (in centimeters) its vertical and horizontal deviations from the center of the target.
8. Work out the values of boresight correction required to compensate for the measured deviation of the center of impact from the center of the target. Table 3-4 contains examples of calculating boresight correction values when firing at ranges of 100m.

TABLE 3-4. CALCULATING BORESIGHT CORRECTIONS (100M FIRE RANGE)

ITEM	DRONE PRO 10X	DRONE PRO 15X
Angular Boresight Increment	0.42 MOA 0.12 Mils	0.3 MOA 0.09 Mils
Boresight Increment in metric units*	1.2cm / 100m 0.44in / 100yd	0.9cm / 100m 0.32in / 100yd
Measured Windage / Elevation Deflection of the Center of Impact from the Target Center	12 cm / 17cm, for example	10 cm / 7cm, for example
Correction Value	Windage	12/1.2≈10 reticle shifts
	Elevation	10/0.9≈11 reticle shifts
		17/1.2≈14 reticle shifts
		7/0.9≈8 reticle shifts

* To calculate boresight increment value in metric units for a fire range R different from 100m, use the coefficient $R/100$. At a range of R (in meters), the boresight increment is $1.2 \times R/100$, cm for Drone Pro 10x and $0.9 \times R/100$, cm for Drone Pro 15x.

9. Use the buttons on the control panel to apply corrections required to bring the center of impact as close as possible to the target center (refer to Figure 3-18).

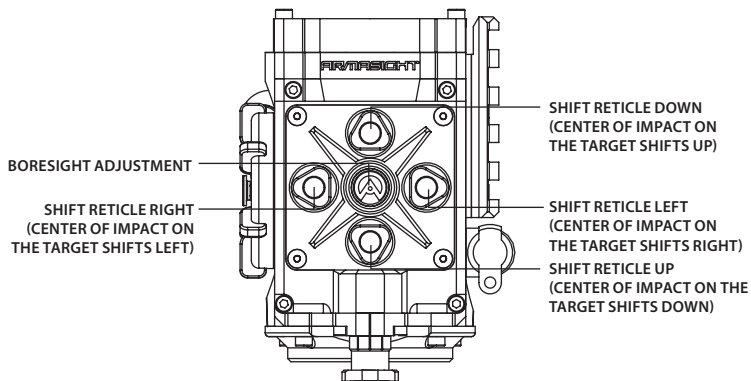

FIGURE 3-18. BORESIGHT ADJUSTMENT BUTTONS

NOTE:

Remember that **the center of impact on the target shifts in the opposite direction from the direction that the reticle shifts**. To bring the center of impact to the right/left and up/down, you must shift the reticle to the left/right and down/up, respectively. Another way of describing this is that wherever the rounds impact on your target, the reticle must be moved from its previous position onto the centre of the point of impact of the rounds.

While holding down the central boresight adjustment button, push the up/down and right/left buttons (as in the figure) the necessary number of times to shift the reticle in the display. To control the shifting of the reticle, check the running coordinate of the reticle center that is shown in the lower left-hand corner of the display.

NOTE:

For display coordinates, the origin is the center of the display. The running coordinate of the reticle is the number of incremental shifts of the reticle from the center of the display. The minus (-) sign appears before the displayed number when the reticle shifts left or down (**the center of impact on the target shifts right or up, respectively**).

10. Fire a series of shots to check the boresight.
11. After completing, save your boresight settings by pushing the “save” combination of buttons (Right+Left). The SAVE indication will appear in the display, when it does, release the buttons. You must save your adjustments straight away – if the unit is turned off (or batteries run out) before you save your adjustments, any adjustment will be lost and unit will display the last “saved” settings when powered up again.
12. After completing the boresight adjustment procedure, turn off the Drone PRO and place the cap over the objective lens.

3.3.3 OPERATING THE IR ILLUMINATOR

Use an IR illuminator when there is little to no ambient light.

CAUTION:

The IR illuminator infrared light will be invisible to the naked eye. The light can, however, be detected by other night vision devices.

CAUTION:

DO NOT leave the IR illuminator activated in the ON position if it is not being used.

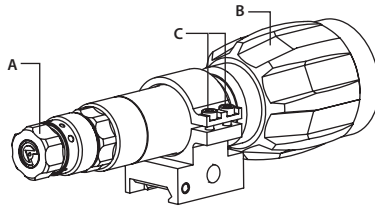

FIGURE 3-19. IR ILLUMINATOR ADJUSTMENT

Operate the IR illuminator as follows:

1. Turn on the IR illuminator by rotating the power switch (A) from OFF position.
2. To change the power level, turn the power switch to one of the spots between the two OFF positions.
3. To adjust IR beam divergence, turn the objective lens of IR illuminator (B).
4. To adjust the IR spot position in the field of view, loosen the two clamp screws (C) and tilt the IR illuminator as required in the spherical clamp hinge. Tighten the screws using a 2.5 mm hex key.

3.3.4 RANGEFINDER RETICLE

Reticle with interrupted funnel.

Among the available reticle options, the Drone PRO 10x is equipped with a reticle with interrupted funnel and rear-sight windage and ballistic scales (BDC).

Interrupted scale is based on 19 inch size (48sm), which is equal to average width of men shoulders.

To determine the distance adjust your size to the object that has the horizontal size of 19 inch. If the object fits between a pair of short lines on the horizontal scale as shown in Figure 3-20, the distance is 100 yd/m.

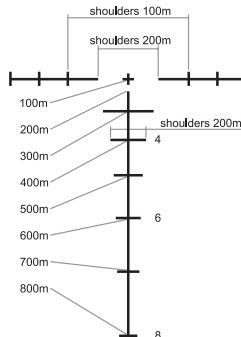

FIGURE 3-20. RANGEFINDER RETICLE

If the object fits the inner ends of the scale, then the distance is 200 yd/m (Figure 3-20).

The length of lines on vertical scale equals 19 inch on distances 300, 400 (marked with numeral 4), 500, 600 (marked with numeral 6), 700 and 800 yd/m (marked with numeral 8).

The vertical ballistic corrections scale allows aiming at ranges up to 800 yd/m without introducing amendments.

For shooting at a distance of 100 yd/m (blank range) align central crosshair with aiming point.

For shooting at a distance of 200 yd/m align the upper end of the vertical scale with the point of impact (Figure 3-21).

For shooting at a distance of 400 yd/m align the crosshair, formed by the line marked with numeral 4 with aiming point (Figure 3-21).

For shooting at distances 300, 500, 600, 700 and 800 yd/m align crosshairs of the corresponding lines with aiming point.

Horizontal scale allows amending corrections of lines when shooting. Graduation of horizontal scale is 1mrad (1 mil).

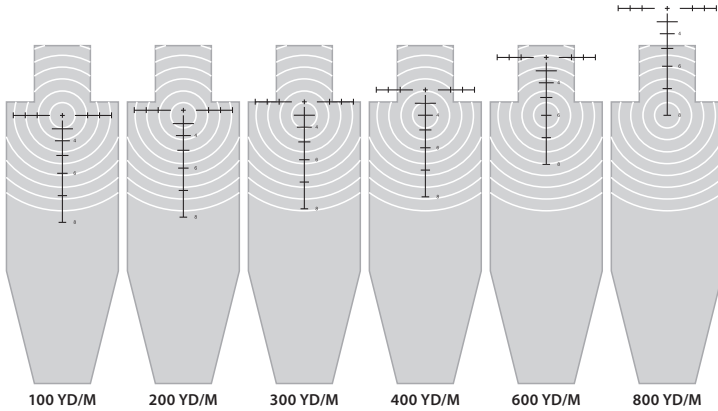

FIGURE 3-21. RANGEFINDER RETICLE USING

3.3.5 DRONE PRO SHUT-DOWN

NOTE:

Shut down the Drone PRO properly to avoid losing unsaved settings and data.

Shut-down the Drone PRO as follows:

1. Make sure any setting changes have been saved.
2. Turn off the Drone PRO.
3. Replace the cap on the objective lens.
4. Disconnect the cable (if applicable).
5. Place the cap on the connector.
6. Dismount the Drone PRO from the weapon.
7. Remove the batteries.

CAUTION:

Do not store the Drone PRO with the batteries still installed.

8. Store the Drone PRO and all accessories in the carrying case.

PREVENTIVE MAINTENANCE AND TROUBLESHOOTING

4.1 PREVENTIVE MAINTENANCE CHECKS AND SERVICES

4.1.1 PREVENTIVE MAINTENANCE CHECKS AND SERVICES (PMCS)

Table 4-1 Preventive Maintenance Checks and Services (PMCS), have been provided so that you can keep your equipment in good operating condition.

Perform functional tests in the order listed in Table 4-1.

Operating procedures are detailed in Chapter 3.

Explanation of Table Entries:

SEQ NO. column. Sequence numbers are for reference and appear in the order required to perform checks and services.

LOCATION OF ITEM TO CHECK/ SERVICE column. Indicates the location and the item to be checked or serviced.

PROCEDURE column. Details the check/ service procedure.

NOT FULLY MISSION CAPABLE IF... column. Indicates what faults will prevent your equipment from operating successfully.

TABLE 4-1. PREVENTIVE MAINTENANCE CHECKS AND SERVICES

SEQ NO.	LOCATION OF ITEM TO CHECK/ SERVICE	PROCEDURE	NOT FULLY MISSION CAPABLE IF...
PRE-OPERATION CHECKS			
1	Completeness	Open storage/carrying case and inventory items by comparing them with the data specified in this manual.	Missing items.
2	Soft Carrying Case	Shake out loose dirt or foreign material. Inspect for tears, cuts, excess wear or damage.	
3	Body	Inspect for cracks or damage. Scratches and gouges are OK if operation is not affected. Inspect for missing parts. Clean as required.	Cracked or damaged. Missing parts.
4	Objective Lens Cap	Inspect for cuts, tears and dirt. Clean as required.	Cap is torn or cut. Cap is not secured to the housing of the lens.
5	Eyecup	Inspect for cuts, tears and dirt. Inspect for torn, bent or improperly fitting eyecup. Clean as required.	Cup is torn or cut.

TABLE 4-1. CONTINUED

SEQ NO.	LOCATION OF ITEM TO CHECK/ SERVICE	PROCEDURE	NOT FULLY MISSION CAPABLE IF...
6	Battery Compartment and Cap	Inspect for corrosion, moisture, and corroded or defective contacts. Inspect for cap damaged or retainer breaks. Inspect rubber gasket for damage.	Contacts are damaged or corroded. Retainer is broken. Cap or rubber gasket is damaged.
7	Lenses	Inspect for cleanliness, scratches, chips or cracks. Clean as required.	Chipped or cracked. Scratches hinder visibility.
8	Focus Knob (Ring)	Check to ensure there is free rotation through full range of travel.	Knob (ring) gets stuck, is too loose, or adversely affects the user's ability to properly focus the objective lens.
9	Eyepiece Focus Ring	Rotate eyepiece focus ring to ensure the ring is not too tight or too loose. Range is approximately 2 turns.	Ring gets stuck, are too loose, or adversely affects the user's ability to properly adjust the diopter.
10	Turn-Pull Switch	Check for operation (without batteries).	Switch is inoperative.
11	Connector	Inspect for corrosion, moisture, and corroded or defective contacts. Inspect for cap damage or retainer breaks.	Contacts are damaged or corroded. Cap is damaged. Retainer is broken.
12	Mount	Inspect for damage or corrosion, for missing parts. Check for proper operation and attachment security.	Damaged. Missing parts. Clamping device is inoperative.
13	Remote Control Unit	Check for damage and missing parts. Check Velcro tape for wear.	Damaged. Missing parts.
14	Color Filter	Inspect the filter lens optical surfaces for cleanliness, scratches, chips or cracks. Clean as required. Check ease of attaching and removal of the lens. Clean as required.	Chipped or cracked. Scratches hinder vision through the equipment. Damaged.
15	Long Range IR Illuminator	Inspect the body of the IR illuminator and mount for damage and missing parts. Check IR Illuminator Power Switch for proper operation. Check IR Illuminator Battery Cap and O-ring for damage., Inspect IR Illuminator lens for cleanliness, scratches, chips or cracks. Clean as required. Check to ensure there is free rotation through the full range of travel (one turn).	Damaged. Missing parts. Switch is inoperative. O-ring is damaged or missing. Lens is chipped or cracked. Lens is sticking or too loose when turned.
16	Platform Ring	Inspect for damage, corrosion, or missing parts. Check for proper operation. Clean as required.	Damaged. Missing parts.
17	Video Cable	Inspect for damage. Inspect the cable connector for corrosion, moisture, and corroded or defective contacts. Clean as required.	Damaged.

OPERATIONAL CHECKS

NOTE:

For a complete operational check, it is necessary to connect a video monitor to the Drone PRO.

18	Turn-Pull Switch	Install the batteries. Remove the objective lens cap. Point the equipment at an object. Turn the equipment on. Look for an image on the display. Look for a flashing battery icon in the eyepiece viewing area.	No image. Battery icon is flashing (indicates a low battery).
19	Focus Knob (Ring)	Turn to the equipment on. Rotate the knob (ring) to ensure it adjusts for focus.	Knob (ring) does not adjust for focus.
20	Eyepiece Focus Ring	Turn the equipment on. Rotate the eyepiece ring to ensure it adjusts the diopter.	Ring does not adjust the diopter.
21	Control Board	Ensure the Drone PRO is responsive to control buttons.	Unresponsive buttons.
22	Remote Control	Turn the equipment to standby. Point the Drone PRO at an object. Press the remote control button. Look for an image on the display. Press the button again. Turn off the equipment.	No image.
23	Video Cable	Connect an external monitor to the Drone PRO. Point the equipment on an object. Turn the equipment on. Look for an image on the monitor. Turn off the Drone PRO. Disconnect the monitor.	No image.
24	Boresight	Test boresight as per Part 4.3.3.	
25	Long Range IR Illuminator	Insert the battery. Mount the IR illuminator onto the Drone PRO. Turn the IR illuminator on. Direct the radiated beam at a wall from a distance of about 5 m. Look through the Drone PRO. A square of light should appear on the wall.	No light appears on the wall.

TABLE 4-1. CONTINUED

SEQ NO.	LOCATION OF ITEM TO CHECK/ SERVICE	PROCEDURE	NOT FULLY MISSION CAPABLE IF...
POST-CHECK PROCEDURES			
		Turn off the equipment.	
		Replace the objective lens cap.	
		Remove the batteries.	
		Return the equipment and all accessories to the carrying case.	

4.2 OPERATOR TROUBLESHOOTING

The purpose of troubleshooting is to identify the most frequent equipment malfunctions, probable causes, and corrective actions required.

Table 4-2 lists the common malfunctions that may be found during the operation or maintenance of the Drone PRO. Perform the tests/inspections and corrective actions in the order listed.

This table does not list all of the malfunctions that may occur with your device, or all of the tests and corrective actions that may be necessary. If you experience an equipment malfunction that is not listed, or is not fixed by the corrective actions listed in the table, please contact Armasight’s Customer Service center.

TABLE 4-2. OPERATOR TROUBLESHOOTING

MALFUNCTION	PROBABLE CAUSE/TEST/INSPECTION	CORRECTIVE ACTION
The Drone PRO fails to activate.	Batteries are missing or improperly installed.	Insert batteries or install correctly.
	Batteries are dead.	Replace the batteries.
	Batteries, surfaces or contacts are dirty or corroded.	Clean the contact surfaces with a pencil eraser and/or alcohol and cotton swabs.
	Remote control unit is damaged.	Please contact Customer Support.
	Remote control battery is dead.	Replace the battery as per Part 4.3.4.
The Drone PRO is not responsive to control buttons.	The equipment is damaged.	Please contact Customer Support.
	The equipment is damaged.	Please contact Customer Support.
Remote control does not work.	Batteries are missing or improperly installed.	Insert batteries or install correctly.
	Batteries are dead.	Replace the batteries.
	Batteries surfaces or contacts are dirty or corroded.	Clean the contact surfaces with a pencil eraser and/or alcohol and cotton swabs.
	Remote control unit is damaged.	Please contact Customer Support.
Poor image quality.	Check objective lens and eyepiece focus.	Refocus.
	Check for fogging or dirt on objective lens and eyepiece.	Clean the lenses as detailed in Part 4.3.2.
	The equipment is damaged.	Please contact Customer Support.
No image on an external monitor.	Video cable is damaged.	Replace the video cable with a new one. Please contact Customer Support.
	The equipment is damaged.	Please contact Customer Support.
Hindered rotation of the battery cap.	Dirty cap thread.	Clean the thread.
	Damaged cap thread.	Replace the cap with a new one. Please contact Customer Support.
Light is visible around eyecup.	Check eyecup resilience.	If the eyecup is defective, please contact Customer Support.

4.3 MAINTENANCE

4.3.1 GENERAL

The Drone PRO operator maintenance consists of operational tests, inspections for unit serviceability, cleaning and mounting procedures, corrective actions (troubleshooting and replacement of a limited number of parts). Maintenance instructions covered elsewhere in this manual (PMCS, troubleshooting, etc.) are not repeated in this section.

CAUTION:

The Drone PRO is a precision electro-optical instrument and must be handled carefully at all times to prevent damage.

CAUTION:

DO NOT dismantle the equipment.

4.3.2 CLEANING PROCEDURES

Clean the Drone PRO and optional items as follows:

1. Gently brush off any dirt from the equipment using only a clean, soft cloth.
2. Moisten the cloth with fresh water and gently wipe the external surfaces (**except** for optical surfaces).
3. Dry any wet surfaces (**except** for optical surfaces) with another clean, dry soft cloth.
4. Using a lens brush, carefully remove all loose dirt from optical surfaces (objective lens and eyepiece).
5. Slightly dampen a cotton swab with ethanol and lightly and slowly wipe optical surfaces. Clean optical surfaces using circular movements, starting from the center and moving out towards the edge, not touching the lens holder and changing the cotton swab after each circular stroke. Repeat until the optical surface is clean.
6. Clean the battery contact surfaces and contact springs with a pencil eraser and/or alcohol and cotton swabs.

CAUTION:

Thoroughly dry each item before replacing into the storage/carrying case.

4.3.3 BORE SIGHTING

Perform the Drone PRO bore sighting:

- When the Drone PRO is mounted to a weapon for the first time;
- After repair of the Drone PRO/weapon;
- As the need arises (in case of systematic inaccuracy and missing the target).

Refer to Part 3.3.2 for boresight procedure.

4.3.4 BATTERY REMOVAL AND REPLACEMENT

Refer to Part 3.1.1 for battery installation procedures.

Refer to Part 3.1.8 for IR illuminator battery installation procedure.

Fully charge the 18650 rechargeable battery before installing in XLR-IR850 illuminator. Insert battery into charger, aligning the polarity symbols on the battery with the polarity symbols on the charger. Never install battery backwards.

Connect power cord to an appropriate power source. Indicator light will flash red when a battery is charging, and will change to green when battery has been fully charged. Remove the battery promptly after charging has been completed.

CAUTION:

Use only the supplied battery, and do not install any other types.

Keep the lithium batteries well away from flames or extreme heat or combustible materials. If handled or recharged incorrectly, lithium ion batteries can cause fires, explosions, property damage, injuries, and death.

Keep the batteries and charger well away from water or liquids of any kind. Exposure to water may cause shock hazards and fatal electrocution.

Do not leave lithium ion rechargeable batteries and chargers unattended while recharging. Do not operate the charger on wood, carpet, fabric, or any other soft or flammable surfaces.

Do not attempt to recharge disposable lithium batteries. Do not use any unprotected lithium ion rechargeable batteries. Never recharge lithium ion batteries in any chargers other than those designed for the specific battery types being used.

Replace the remote control battery as follows:

1. Using a screwdriver, unscrew the four screws (A, Figure 4-1) that secure the cover to the bottom of the unit. Remove the cover.
2. Replace the battery with new one (CR2032, 3V). Install the battery, aligning their polarity markings (+/-) with those embossed on the compartment.
3. Replace the cover and tighten the screws (A).

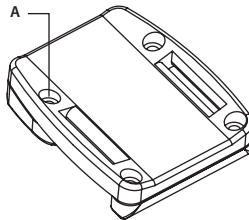

FIGURE 4-1. ADVANCED WIRELESS REMOTE CONTROL BATTERY INSTALLATION

4.4 RETURN INSTRUCTIONS

For service, repair or replacement, please email: service@armasight.com.

To assist the Service Representative (SR) with determining if the item is repairable, please provide the following information:

1. Serial Number of the defective item (engraved on bottom of the equipment).
2. Thorough description of the malfunction, defect or damage.
3. An explanation of how the malfunction, defect or damage occurred, if known.

If the SR determines that the item is under warranty or should be returned for repair, a Return Material Authorization number (RMA#) will be provided.

When returning the Drone PRO for service or repair, the following procedures should be followed to prevent any additional damage:

1. Make sure the Drone PRO is free of all contaminants such as dirt or any other foreign material.
2. Remove the batteries.

3. Place the cap over the objective lens.
4. Place the Drone PRO and accessories in the carrying case.

Place the Drone PRO and a copy of the test report or detailed description of the failure in a suitable packing/shipping container. Mark the package with the RMA#. Ship the fastest, traceable, prepaid means to:

Armasight Inc.
815 Dubuque Avenue
South San Francisco, CA 94080
USA

A. LIST OF SPARE PARTS

The parts authorized by this list of spare parts are required for operator maintenance. The list includes parts that must be removed before replacing authorized parts.

The PART NO. column indicates the primary number used by the manufacturer, which controls the design and characteristics of the item in terms of its engineering drawings, specifications, standards, and inspection requirement, to identify an item.

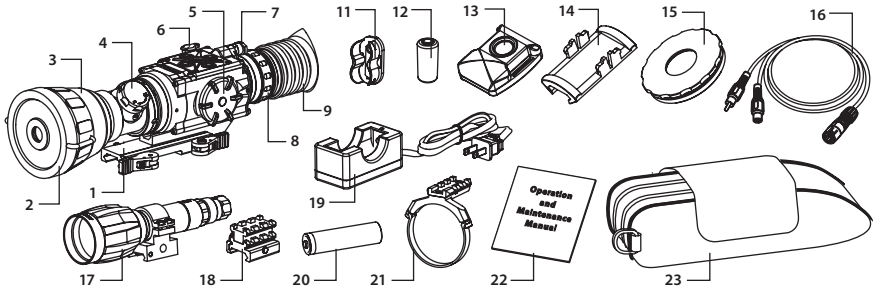

FIGURE A-1. DRONE PRO SPARE PARTS LIST

TABLE A-1. DRONE PRO SPARE PARTS LIST

ITEM NO.	DESCRIPTION	PART NO.
1	Mount	ADPSQRM2
2	108mm Objective Lens Cap	ADPS10OLC
-	145mm Objective Lens Cap	ADPS15OLC
3	108mm Objective Lens Assembly	ADPS10OLA
-	145mm Objective Lens Assembly	ADPS15OLA
4	Objective Focus Knob	ADPS10OFK
5	Battery Cap	ADPSBC
6	Connector Cap	ADPSCNCP
7	Turn-Pull Switch	ADPSSWT
8	Eyepiece Assembly	ADPSEPA
9	Eyecup	ADPSEC
10	Side Picatinny/ Weaver Rail (not shown)	ADPSPRL
11	Battery Cassette	ADPSBTCS
12	CR123A Lithium Battery	ALT
13	Advanced Wireless Remote Control	ANVR000001

TABLE A-1. CONTINUED

ITEM NO.	DESCRIPTION	PART NO.
14	Picatinny Adapter for Advanced Wireless Remote Control	ANRA000002
15	Color (Day Time) Filter for 108mm Lens	ADPCF108
-	Color (Day Time) Filter for 145mm Lens	ADPCF108
16	Video Cable	ATCA000004
17	XLR-IR850 Detachable Long-Range IR Illuminator	IAIR850IR000003
18	Riser for XLR-IR #182	ARSXLR182
19	Charger for 18650 Rechargeable Battery	ALT
20	16650 Rechargeable Battery for XLR-IR850	ALT
21	Platform Ring	ATAM000003
22	Operation and Maintenance Manual	ADPSOMM
23	Carrying Case	AGSC000009

B. PRODUCT WARRANTY REGISTRATION CARD

In order to validate the warranty on your product, Armasight must receive a completed Product Warranty Registration Card for each unit, or the user must complete warranty registration on our website (www.armsight.com). Please complete the included form and immediately mail it to our Service Center:

Armasight Inc.
 815 Dubuque Avenue
 South San Francisco, CA 94080
 USA

ARMASIGHT PRODUCT WARRANTY REGISTRATION CARD

PRODUCT INFORMATION

Product Name _____ Purchased From _____

Purchase Date _____ Product Serial # _____

CUSTOMER INFORMATION

Name _____

Address _____

City _____ Country _____ Zip _____

Day Phone # _____ Home Phone # _____

E-mail address _____

.....
 Customer Signature Required



Armasight Inc.

815 Dubuque Avenue
South San Francisco
CA 94080, USA

Phone: (888)959-2259

Fax: (888)959-2260

Intl Phone/Fax: (650)492-7755

info@armasight.com



WARNING:

This product contains natural rubber latex which may cause allergic reactions! The FDA has reported an increase in the number of deaths that are associated with an apparent sensitivity to natural latex proteins. If you are allergic to latex, it is a good idea to learn which products contain it and strictly avoid exposure to those products.

www.armasight.com